

MODIFIED H-BRIDGE NINE LEVEL INVERTER WITH LOW SWITCHING FREQUENCY

M.S. Usha Nandhini¹, PG Scholar ; N.Vinothini², PG Scholar ; R.Prakash³, Assistant Professor

Department of EEE, Vivekanandha Institute of Engineering and Technology for Women, Tiruchengode.

Abstract

In this paper a new configuration of the single-phase nine-level voltage source inverter is described. The proposed inverter is based on modified H-bridge converter. To validate the proposed inverter, a low power prototype inverter has been designed and implemented. Instead of sixteen controlled switches as in conventional method, this topology requires only eight switches to obtain nine level output. The reduction of switches lowers switching losses, cost and total harmonic distortions. Performance parameters have been analyzed for the nine level H-bridge MLI. Analytical, simulation and experiment results have been provided.

Keywords

Low switching frequency,
Modified H-bridge converter,
Single-phase nine-level Inverter.

Introduction

Various topologies for multilevel inverter have been proposed over the years, aiming to construct a sinusoidal waveform from several dc-voltage levels; diode clamped multilevel inverter, flying capacitor multilevel inverter, cascaded H-bridge multilevel inverter, and modified H-bridge multilevel inverter.

A major problem with diode-clamped inverter configuration is the achievement of a balanced voltage supply within the DC link. A multi-cell or a flying-capacitor multilevel inverter (FCMI) does not require isolated DC sides and additional clamping diodes; snubber-less operation is possible and expansion to multilevel is easy. However, these properties may be limited by voltage unbalancing of flying capacitors, which is the most serious problem. Therefore, the FCMI has to ensure voltage balancing of the flying capacitors, under all operating conditions. A cascaded multilevel inverter is made up of a series of H-bridge (single-phase full-bridge) inverters, each with their own isolated dc-bus. The multilevel inverter can generate almost-sinusoidal

waveform voltage from several separate dc sources (SDCSs), which may be obtained from solar cells, fuel cells, batteries, ultra capacitors, etc.

Advantages of a cascaded multilevel inverter includes: (1) its active devices switching at (or nearly) the fundamental frequency, drastically reducing switching losses, (2) elimination of the transformer in providing required voltage levels, (3) easier packaging due to the simplicity of its structure and its low component-count, and (4) much faster response, as there are no transformers. However, it has limitations, such as the large number of inverters required to decrease harmonics, and a complex dc-voltage regulation loop; the separate dc sources it needs for real power conversion somewhat limits its applications.

Single-phase Seven level Inverter

The proposed single-phase seven-level inverter comprises a single-phase conventional full-bridge inverter, two bidirectional switches, and a capacitor voltage divider formed by C_1 , C_2 , and C_3 (see Fig. 1).

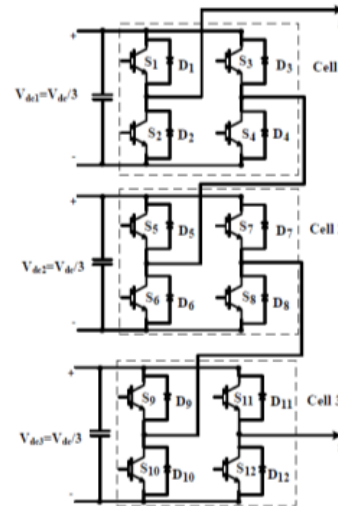

Figure 1. Seven-level cascade Inverter

The development of a novel modified H-bridge single-phase seven-level inverter that has two diode-embedded bidirectional switches. The inverter has seven output-voltage values: zero, one third positive, two third positive, full positive, one third negative, two third negative, and full negative, of the dc supply; so called a seven-level single-phase PWM inverter.

The modified H-bridge topology is significantly advantageous over the other topologies; less power switch, less anti parallel diodes, power diodes, and less capacitors for inverters of the same number of levels. This inverter consists of conventional H-bridge inverter and bidirectional switch. There are several H-bridge multilevel-inverter topologies but in principle they are the same, different from bidirectional switch topology.

Modified H-bridge Inverter

An H bridge is an electronic circuit that enables a voltage to be applied across a load in either direction. These circuits are often used in robotics and other applications to allow DC motors to run forwards and backwards. Most DC-to-AC converters (power inverters), most AC/AC converters, the DC-to-DC push-pull converter, most motor controllers, and many other kinds of power electronics use H bridges. In particular, a bipolar stepper motor is almost invariably driven by a motor controller containing Two H Bridges. Three-phase configuration can be easily implemented by three single-phase structures. Cascade configuration has been attracted for medium and high voltage renewable energy systems such as photovoltaic, due to its modular and simple structure. A higher level can easily be implemented by adding classical H-bridge cells in this configuration.

However, it needs additional DC voltage sources and switching devices which can increase the cost of the system. The main features of Cascaded H-bridge multilevel inverter are, for real power conversions from ac to dc and then dc to ac, the cascaded inverter needs separate dc sources. The structure of separate dc sources is well suited for renewable energy sources such as fuel cell, photovoltaic and biomass. Compared with the diode clamped and flying capacitor types, it requires the least number of components to achieve the same number of voltage levels.

Soft switching techniques can be used to reduce switching losses and device stresses. The advantages are 1).Its active devices switching at (or nearly) the fundamental frequency, drastically reducing switching losses. 2).Elimination of the transformer in providing required voltage levels. 3).Easier packaging due to the simplicity of its structure and its low component-count.

9-Level Inverter topology description

The general structure of the Modified cascaded H-bridge multilevel inverter is shown in Figure 2. This inverter consists of an H Bridge and multi conversion cell which consists of four separate voltage sources (V_{dc1} , V_{dc2} , V_{dc3} and V_{dc4}), four switches and four diodes.

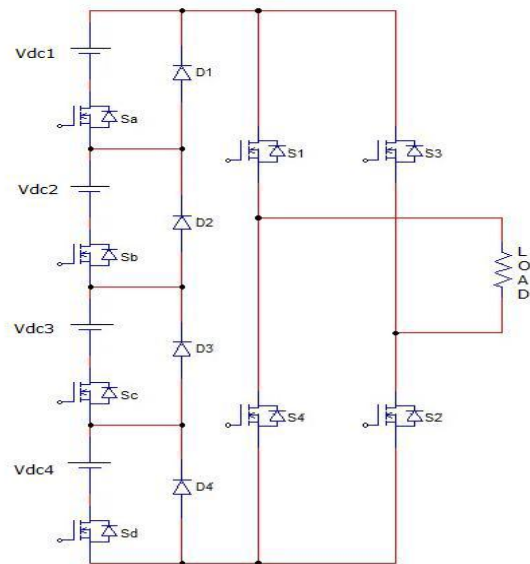

Figure 2. 9-Level Modified-Cascaded multilevel inverter

Each source connected in cascade with other sources through a circuit consists of one active switch and one diode that can make the output voltage source only in positive polarity with several levels. Only one H-bridge is connected with multi conversion cell to acquire both positive and negative polarity.

By turning on controlled switches S1 (S2, S3 and S4 turn off) the output voltage +1Vdc (first level) is produced across the load. Similarly turning on of switches S1, S2 (S3 & S4 turn off) +2Vdc (second level) output is produced across the load. Similarly +3Vdc levels can be achieved by turning on S1, S2, S3 switches (S4 turn off) and +4Vdc levels can be achieved by turning on S1, S2, S3 & S4 as shown in below Table 1.

S. No	Multi conversion Cell		H-Bridge		Voltage levels
	On switches	Off switches	On switches	Off switches	
1	S1, S2, S3, S4	D1,D2,D3, D4	Q1,Q2	Q3,Q4	+4Vdc
2	S1, S2, S3, D4	S4,D1,D2, D3	Q1,Q2	Q3,Q4	+3Vdc
3	S1, S2, D3, D4	S3, S4,D1,D2	Q1,Q2	Q3,Q4	+2Vdc
4	S1, D2, D3,D4	S2, S3, S4,D1	Q1,Q2	Q3,Q4	+1Vdc
5	D1, D2, D3,D4	S1, S2, S3,S4	Q1,Q2	Q3,Q4	0
6	S1, D2, D3,D4	S2, S3, S4,D1	Q3,Q4	Q1,Q2	-1Vdc
7	S1, S2, D3,D4	S3, S4,D1,D2	Q3,Q4	Q1,Q2	-2Vdc
8	S1, S2, S3, D4	S4,D1,D2, D3	Q3,Q4	Q1,Q2	-3Vdc
9	S1, S2, S3, S4	D1,D2,D3, D4	Q3,Q4	Q1,Q2	-4Vdc

Table 1. Switching Patterns for 9 levels MC-MLI

From the above table, it is observed that for each voltage level, among the paralleled switches only one switch is switched ON. The input DC voltage is converted into a stepped DC voltage, by the multi conversion cell, which is further processed by the H Bridge and outputted as a stepped or approximately sinusoidal AC waveform. In the H Bridge, during the positive cycle, only the switches Q1 and Q3 are switched on. And during the negative half cycle, only the switches Q2 and Q4 are switched on. The S number of DC sources or stages and the associated number output level can be calculated by using the equation as follows,

$$N_{level} = 2S + 1 \tag{1}$$

For an example, if S=3, the output wave form will have seven levels ($\pm 3V_{dc}$, $\pm 2V_{dc}$, $\pm 1V_{dc}$ and 0). Similarly voltage on each stage can be calculated by using the equation as given,

$$A_i = 1 \text{ V dc } (1, 2, 3) \tag{2}$$

The main advantage of proposed modified cascaded multi-level inverter is seven levels with only use of seven switches. For an example, if S=3, the output wave form will have seven levels ($\pm 3V_{dc}$, $\pm 2V_{dc}$, $\pm 1V_{dc}$ and 0). The number switches used in this topology is given by the equation as follows

$$N_{Switch} = 2S + 4 \tag{3}$$

Simulation and Experimental results

New designs of power electronics systems are the norm due to new applications and lack of standardization in specifications is because of varying customer demands. Accurate simulation is necessary to minimize costly repetitions of designs and bread boarding and hence reduce the overall cost and the concept-to-production time. We can collect performance data while simulating our model and then generate a simulation profile report based on the collected data that shows how much time Simulink takes to execute each simulation method.

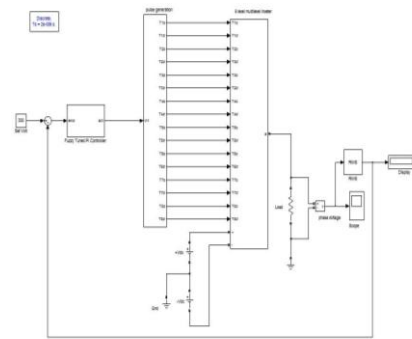

Figure 3. Simulation Circuit

The figure 3 shows the simulation circuit of modified H bridge nine level inverter circuit with resistive load. It consists of fuzzy tuned PI controller with set volt as 300 set voltage can be varied as desired. Feedback is taken from the output. controller generates control signal depending on the error switching circuit is reduced in this circuit. display is used to show the output value. The circuit has nine level inverter.

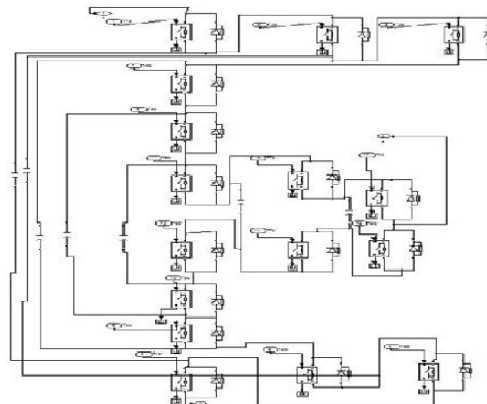

Figure 4. Subsystem 1

The below figure 4 shows circuit of subsystem 1 which is present in the main simulation circuit. This circuit shows nine level inverter. This capability simplifies the creation and management of designs that share components, as one model can represent a family of designs. Conditionally executed subsystems let it change system dynamics by enabling or disabling specific sections of design via controlling logic signals. Simulink lets it create control signals that can enable or trigger the execution of the subsystem based on specific time or events.

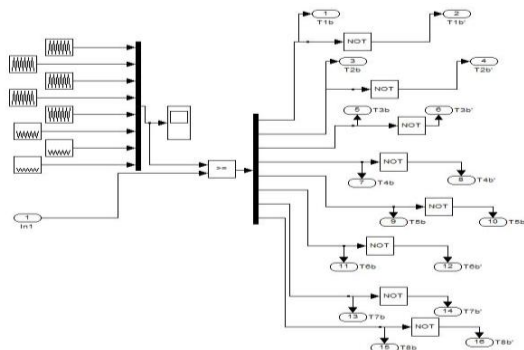

Figure 5. Subsystem 2

The figure 5 shows subsystem 2. These include blocks for creating simulation tests. For example, the Signal Builder block lets we graphically create waveforms to exercise models. Using the Signal & Scope Manager, we can inject signals into your model, as well as log and view signals, without adding blocks. Simulink also provides model verification blocks to check that block outputs conform to our design requirements. The figure 6 (i.e) graph shows the nine level output voltage waveform.

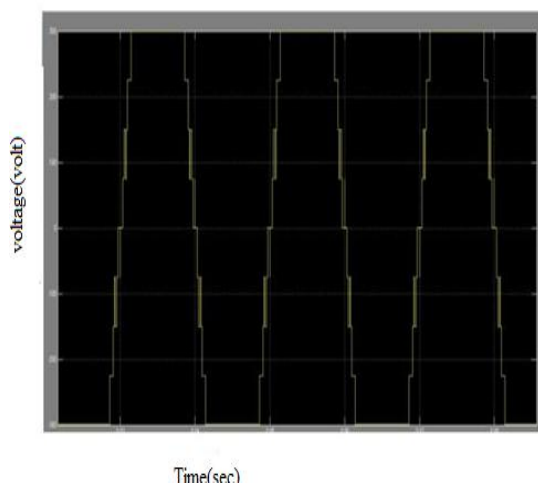

Figure 6 Voltage waveform

Simulation result prove that the proposed nine-level inverter based on conventional H-bridge inverter and the bidirectional switches operates as proposed. Through simulation it is seen that proposed inverter topology generates a high quality voltage waveform. Output voltage of inverter without filter is nearly sinusoidal waveform. It reduces dv/dt stress imposed on power switching devices. In this work, nine level inverter has been used. Further increasing the number of levels will improve the shape of the output waveform to be more sinusoidal. So the number of levels can be increased to improve the quality of output voltage waveform. The switching circuits can be reduced further. The number of switching devices can be reduced. These are maximum possibilities of future work.

References

- [1] Ceglia, G. ; Guzman, V. ; Sanchez, C. ; Ibanez, F. ; Walter, J.; Gimenez, M.I. "A New Simplified Multi-level Inverter Topology for DC-AC Conversion" in Power Electronics, IEEE Transactions on vol .21,no.5,2006.
- [2] Choi, N.S. ; Cho, J.G. ; Cho, Gyu H. "A general circuit topology of multilevel inverter" in Power Electronics Specialists Conference, 1991. PESC '91 Record, 22nd Annual IEEE 1991.
- [3] Lezana, P. ; Rodriguez, J. ; Oyarzun, D.A. "Cascaded multilevel inverter with regeneration capability and reduced number of switches" in Industrial Electronics, IEEE Transactions on vol.55,no .3,march 2008.
- [4] Jan. McGrath, B.P. ; Holmes, D.G. "Analytical modeling of voltage balance dynamics for a flying capacitor multilevel converter" in Power Electronics, IEEE Transactions on vol.23,no.2, 2008.
- [5] Meynard, T.A. ; Foch, H. "Multi-level conversion: high-voltage chopper and voltage-source inverters" Power Electronics Specialists Conference, 1992. PESC '92 Record, 23rd Annual IEEE 1992.
- [6] Nabae, A. ; Takahashi, I. ; Akagi, H. "A new neutral-point-clamped PWM inverter" in Industry Applications, IEEE Transactions on vol.IA-17,no.5,1981.
- [7] Odeh, C.I. ; Nnadi, D.B.N. "Single-phase 9-level hybridised cascaded multilevel Inverter" in PowerElectronics,vol.6,no.3,IET 2013.
- [8] Villanueva, E. ; Correa, P. ; Rodriguez, J. ; Pacas, M. "Control of a single-phase cascaded H-bridge multilevel inverter for grid-connected photovoltaic systems" in Industrial Electronics, IEEE Transactions on vol.56,no.11,2009.
- [9] P. Vas, Vector Control of AC Machines. Clarendon Press, Oxford University Press (Oxford [England], New York) 1990.

Conclusion

- [10] Yaosuo Xue ; Manjrekar, M. "A New Class of Single-Phase Multilevel Inverters" in Power Electronics for Distributed Generation Systems (PEDG), 2nd IEEE International Symposium on 2010.
- [11] J. Liao and M. Ferdowsi, "An improved cascaded H-bridge multilevel inverter controlled by an unbalanced voltage level sigma-delta modulator," in Proc. IEEE VPPC, Harbin, China, Sep. 2008, pp. 1-5.
- [12] J. Rodriguez, J. S. Lai, and F. Z. Zeng, "Multilevel inverters: A survey of topologies, controls and applications," IEEE Trans. Ind. Electron., vol. 49, no. 4, pp. 724-738, Aug. 2002.
- [13] F. Z. Peng, J. W. McKeever, and D. J. Adams, "Cascade multilevel inverters for utility applications," in Proceeding of IEEE IECON 97, 1997, pp. 437-442 vol.2.
- [14] Zh. Du, L. M. Tolbert, J. N. Chiasson, and B. Ozpineci, "A cascade multilevel inverter using a single DC source ," in Proceeding of 21st Annual IEEE APEC06, March 2006, pp. 426-430.
- [15] M. D. Manjrekar, P. K. Steimer, and T. A. Lipo, "Hybrid multilevel power conversion system: a competitive solution for high-power applications," IEEE Transaction on Ind. Appl., vol. 36, pp. 834-841, 2000.
- [16] N. S. Choi, J. G. Cho, and G. H. Cho, "A general circuit topology of multilevel inverter," in Proceeding of IEEE PESC '91 , 1991, pp. 96-103.
- Drives from Bannari Amman Institute of Technology affiliated to Anna University Chennai in the year 2010, respectively. Currently, He is working as an Assistant Professor in EEE Department at Vivekanandha Institute of Engineering and Technology for women. His teaching and research areas include Power Electronics, Electrical Machines and Special Machines.

Biographies

M.S.USHA NANDHINI received the B.E. degree in Electrical and Electronics Engineering from K.S.R. College of Engineering affiliated to Anna University Chennai, in the year 2012. Currently, She is pursuing her M.E. in Power Electronics and Drives under Anna University Chennai. Her research area includes Power Electronics and Electrical Machines, etc.

N.VINOTHINI received the B.E. degree in Electrical and Electronics Engineering from Sri Krishna College of Technology affiliated to Anna University Chennai, in the year 2012. Currently, She is pursuing her M.E. in Power Electronics and Drives under Anna University Chennai. Her research area includes Electrical Machines and Power Systems control, etc. She is currently doing project in the area of Unified Power Flow Controller modeling for power quality improvement.

R.PRAKASH received the B.E. degree in Electrical and Electronics Engineering from Annamalai University in the year 2007 and the M.E. degree in Power Electronics and